

CERATHERM 600-3

Radiant Heater

Instruction Manual



**FOR THE OPERATORS AND THOSE RESPONSIBLE FOR THE CARE
AND MAINTENANCE OF THIS UNIT:**

- Read through this **instruction manual** thoroughly before using the unit.
- Keep this **instruction manual** in a place where it can be referred to whenever needed.

Contents

1. INTRODUCTION	4
1.1 GENERAL.....	4
1.2 PURPOSE.....	4
1.3 ELECTROMAGNETIC EMISSIONS AND ELECTROMAGNETIC COMPATIBILITY	4
1.4 SCOPE OF DELIVERY	5
1.5 MAINTENANCE PROCEDURE	5
1.6 SUPPORT.....	5
2. DEFINITIONS AND SYMBOLS	6
2.1 DEFINITIONS	6
2.2 SYMBOLS.....	6
3. SAFETY GUIDELINES	9
4. GENERAL DESCRIPTION	13
5. ASSEMBLY	13
5.1 MINIMUM CLEARANCE.....	13
6. PRODUCT DESCRIPTION	14
6.1 DESCRIPTION OF PARTS.....	15
7. OPERATION	17
7.1 MASTER SWITCH.....	17
7.2 CONTROL ELEMENTS ON THE FRONT.....	18
8. COMMISSIONING	19
8.1 ADJUSTING THE HEAT OUTPUT	19
8.2 PRACTICAL EXAMPLES OF OUTPUT LEVEL SETTINGS.....	20
8.3 CHECKING THE SET OUTPUT	20
8.4 ALARM MONITORING.....	20
9. LED LIGHTING	21
9.1 OPERATION.....	21
9.2 CHANGING THE BRIGHTNESS VALUES.....	21
10. TROUBLESHOOTING	22
11. TESTING THE CONTROL ELEMENTS	23
12. CLEANING/DISINFECTION	24
12.1 GENERAL INFORMATION	24
13. WARRANTY	25
13.1 WARRANTY PERIOD	25
13.2 WARRANTY RESTRICTIONS.....	25
14. DISPOSING OF THE UNIT	25
15. SPECIFICATIONS*	26

16. ACCESSORIES	27
16.1 WALL MOUNT, FIXED, NON-PIVOTING (OPTIONAL)	27
16.2 WALL MOUNT WITH DOUBLE-JOINT ARM (OPTIONAL)	28
16.3 WALL MOUNT WITH DOUBLE-JOINT ARM, LONG, WITH HEIGHT ADJUSTMENT (OPTIONAL)	28
16.4 CEILING MOUNT WITH DOUBLE-JOINT ARM, LONG, WITH HEIGHT ADJUSTMENT (OPTIONAL).....	29
16.5 MOBILE STAND, WITH HEIGHT ADJUSTMENT (OPTIONAL).....	29
17. REPAIR REQUEST FORM.....	31

1. Introduction

1.1 General

This instruction manual describes the intended use, operation, specifications, care and maintenance of the CERATHERM 600-3 radiant heater.

Read through this instruction manual carefully and familiarise yourself with the content before operating the CERATHERM 600-3. To ensure that the unit is used safely, follow the operating guidelines and explanations that are given in this instruction manual. The CERATHERM 600-3 must only be operated by persons who have been properly trained and instructed, under the supervision of a skilled medical specialist who is familiar with the currently known risks and benefits of using a radiant heater.

NUFER MEDICAL is in no way responsible for errors or accidents that are the result of non-compliance with the instructions on operation, care, maintenance and any other content given in this instruction manual. The same applies for repair work performed on the unit if such work is performed by unauthorised persons or if unapproved original components are used.

The CERATHERM 600-3 must only be used for its intended purpose as per chapter 1.2 of this instruction manual.

Keep this instruction manual in a place where it can be referred to whenever needed. In the event of technical problems or malfunctions, please inform your local NUFER MEDICAL sales partner immediately. If you do not understand the content of this instruction manual, contact your local NUFER MEDICAL sales partner for more information.

1.2 Purpose

The CERATHERM 600-3 radiant heater is designed to preheat examination and baby changing tables and to maintain the body temperature of new-borns, children and adults.

1.3 Electromagnetic Emissions and Electromagnetic Compatibility

The CERATHERM 600-3 radiant heater meets all the requirements of the EN 60601-1-2 industrial standard.

Accordingly, the unit's electromagnetic emissions are very low and cannot impair the functioning of electronic equipment located in the immediate vicinity.

Ensure that any electronic equipment that is used in the vicinity of the CERATHERM 600-3 radiant heater also meets the requirements of EN 60601-1-2. Equipment with electromagnetic emissions that are too high can impair the radiant heater's ability to function safely.

Do not use any wireless communication devices within 5 metres of the radiant heater. The mains power supply to which the CERATHERM 600-3 radiant heater is connected must meet the legal and technical requirements for a hospital or clinic mains power supply in terms of dielectric strength, frequency stability and pulse spikes etc. Ensure that the radiant heater is not exposed to electrostatic discharge.

1.4 Scope of Delivery

The CERATHERM 600-3 radiant heater is supplied with a mains cable, instruction manual and declaration of conformity. Approved accessories are described in chapter 16.

1.5 Maintenance Procedure

No particular maintenance is required for the CERATHERM 600-3 radiant heater, except for the annual safety check described in chapter 20 of the CERATHERM 600-3 service manual. The unit does not have any special wear parts.

1.6 Support

Maintenance for the CERATHERM 600-3 radiant heater must only be performed by persons who have been authorised by NUFER MEDICAL or the local trained sales partner. If repair work is required, the unit must be returned to the NUFER MEDICAL sales partner located in your country, along with a completed 'Repair Request Form' (see chapter 17). Further information is available from the customer service department of:

NUFER MEDICAL AG

Morgenstrasse 148
CH-3018 Bern / Switzerland



Tel. +41 (0)31 958 66 66

info@nufer-medical.ch
www.nufer-medical.ch

2. Definitions and Symbols

2.1 Definitions



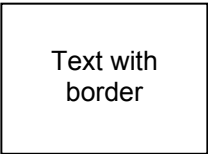

Please take time to familiarise yourself with the definitions given below before you use the radiant heater. The following expressions are used in this instruction manual:







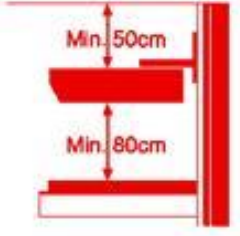



Expression	Symbol	Description
Warning:		This expression is used in the text to draw your attention to hazardous conditions in connection to the operation, cleaning or maintenance of the unit if there is a risk of injury or death for the operator or the patient.
Caution:		This expression is used in the text to draw your attention to a process that must be followed exactly to avoid injury to the user or patient, or damage to the unit.
Note:		This expression is used in the text to draw your attention to processes or conditions that you could otherwise overlook or misunderstand.



2.2 Symbols

Please take time to familiarise yourself with the symbols given below before you use the radiant heater. This list includes all the symbols that are displayed on the unit to aid operation or as a warning or note:

Symbol	Explanation
	Ensure that the instruction manual is observed.





	<p>Dangerous voltage.</p>
	<p>Warning sign: Refer to the relevant section of the instruction manual for further information.</p>
	<p>Warning sign: Hot surfaces -> Risk of burns.</p>
	<p>Warning sign: Ensure that there is a clearance of at least 80 cm between the reclining surface and the bottom edge of the heater head. There must be a clearance of at least 50 cm between the ceiling/false ceiling and the top edge of the heater head -> Risk of fire and risk of burns.</p>
	<p>Warning sign: Do not reach into the heater head -> Risk of burns.</p>
	<p>Warning sign: Do not place any objects on the protective grille -> Risk of fire.</p>









	<p>Operation: Switches unit on and off (observe chap. 8) Display: The unit's operating mode (observe chap. 8)</p>
	<p>Operation: Alarm confirmation (observe chap. 8) Display: Alarm (observe chap. 8 and safety guidelines in chap. 2)</p>
	<p>Operation: Preset heat level 1 (20% output) Display: Heat level 1 active</p>
	<p>Operation: Preset heat level 2 (50% output) Display: Heat level 2 active</p>
	<p>Operation: Preset heat level 3 (75% output) Display: Heat level 3 active</p>
	<p>Operation: Preset heat level 4 (98% output) Display: Heat level 4 active</p>
	<p>Display: Heating active (observe chap. 8.3)</p>
	<p>Operation: Lighting 20% on/off (observe chap. 9) Display: None</p>
	<p>Operation: Lighting 100% on/off (observe chap. 9) Display: None</p>
	<p>Operation: Master switch (supply voltage on/off, see chap. 7) Display: Mains supply on</p>
	<p>Potential equalisation connection. If the unit is used in a room that corresponds to Category 3 or 4 under Swiss Low-Voltage Installation Standard NIN / 7.10, this connection must be connected to the room's potential equalisation connection.</p>









 0123	<p>The unit meets the requirements of EU Directive 93/42/EEC/Annex II. Monitoring is provided by TÜV SÜD Product Service GmbH, 80339 München.</p>
	<p>The unit must be disposed of in accordance with EU Directive 2002/96/EC. Get in touch with your allocated NUFER MEDICAL sales partner.</p>











3. Safety guidelines

Please ensure that the following safety guidelines are observed. The guidelines must be observed during the installation and use of the radiant heater:

	<p>The radiant heater must only be connected to a power socket with a protective earth connection. Connection values of the power socket: 230 V AC +/-10%, 50–60 Hz, 6 A.</p>
	<p>The unit is fitted with a ceramic heater that is sensitive to knocks and blows. Ensure that the unit is not exposed to any strong knocks or blows.</p>
	<p>Ensure that the wall mount is fastened into solid masonry and that suitable wall-plug screws are used. Lightweight walls must be appropriately reinforced in the wall-mount area. The client's specialist personnel are responsible for the secure fastening of the radiant heater. -> Risk to user and patient safety.</p>
	<p>Parts must neither be removed from or attached to the radiant heater and no other modifications must be made -> Risk to user and patient safety.</p>
	<p>Ensure that there is a clearance of at least 80 cm between the reclining surface and the bottom edge of the heater head; there must be a clearance of at least 50 cm between the ceiling/false ceiling and the top edge of the heater head -> Risk of fire, risk to user and patient safety.</p>

	<p>The radiant heater may increase patient water loss unnoticeably. It is vital that the patient is constantly monitored by the care staff -> Risk to patient safety.</p>
	<p>Changing the underlay (using dark cloths, heating pads etc.) can result in higher temperatures on the reclining surface and affect the patient's body temperature -> Risk to patient safety.</p>
	<p>Do not touch the patient and the radiant heater simultaneously. Possible potential differences between the unit and the care surface may place patient safety at risk.</p>
	<p>The radiant heater always functions as a manual radiant heater. No patient information is transmitted to the unit during use. The care personnel are therefore responsible for the patient's condition at all times.</p>
	<p>Ensure that no liquids enter the unit. If liquids do enter the inside of the unit, shut the unit down immediately and have it checked by an authorised person and repaired as required. A safety check must be performed before the unit can be used again.</p>
	<p>The radiant heater is fitted with an LED bulb to light up the care surface / the patient's body. Ensure that neither user nor patient look directly into the bulb.</p>
	<p>External conditions can affect the radiant heater's performance. Do not operate the unit at temperatures below +5°C or over +30°C. The relative humidity should not exceed 90%. Ensure that no condensation forms on the unit.</p>
	<p>External conditions (such as temperature and drafts) and other equipment in the vicinity (e.g. phototherapy equipment) can affect the patient's body temperature.</p>

	<p>Ensure that the radiant heater is positioned above the centre of the care surface. Do not operate the radiant heater at a right angle to the care surface.</p>
	<p>The radiant heater must only be used in a horizontal position with heat radiating downwards -> Risk of fire, risk to user and patient safety.</p>
	<p>The radiant heater must not be used in environments that are at risk of fire or explosion, i.e. in the immediate vicinity of anaesthetic gases or other highly flammable gases, liquids or materials -> Risk of fire or risk of explosion.</p>
	<p>The openings in the housing on the top side of the heater head must be kept clear at all times to guarantee sufficient air circulation. Do not lay any cloths, objects or flammable substances on the topside of the heater head -> Risk of fire.</p>
	<p>Never touch the protective grille on the top of the unit or the reflector and heater on the underside of the unit when the heater head is in use. -> Risk of burns, risk to user safety.</p>
	<p>The radiant heater must only be operated by persons who have been properly trained and instructed, under the supervision of a skilled medical specialist who is familiar with the currently known risks and benefits of using a radiant heater -> Risk to user and patient safety.</p>
	<p>The patient must never be left unattended beneath the radiant heater while it is switched on -> Risk to patient safety.</p>
	<p>It is vital that care staff independently monitor the patient's temperature -> Risk to patient safety.</p>

	<p>When the housing of the heater head is removed, there is a risk of electric shock. The unit's mains cable must always be disconnected before the housing of the heater head is opened.</p>
	<p>When the heater head has been on for 15 minutes, an acoustic and visual alarm is activated. The alarm can be delayed for a further 15 minutes by pressing the  button.</p>
	<p>When the radiant heater is being used above infant incubators or heating beds, it must be ensured that there is sufficient clearance between the bottom edge of the heater head and any heat-sensitive materials such as Plexiglas or acrylic glass. Ensure that there is at least 80 cm clearance at all times. Set the heat output no higher than level 3 (75%).</p>
	<p>The radiant heater must only be operated with original accessories that NUFER MEDICAL has expressly approved for use with the CERATHERM 600-3. Observe the relevant information in chapter 16.</p>
	<p>In the event of a technical alarm  shut the unit down immediately and have it checked by an authorised person and repaired as required. A safety check must be performed before the unit can be used again.</p>
	<p>Before any cleaning or disinfection is performed, ensure that the unit is shut down and disconnected from the mains supply. Observe the relevant information in chapter 12.</p>
	<p>Repair and maintenance work must only be performed on the radiant heater by authorised personnel. Only components that NUFER MEDICAL has expressly approved for use with the CERATHERM 600-3 may be used.</p>
	<p>After the unit is decommissioned, it must be disposed of correctly in accordance with EU Directive 2002/96/EC. Get in touch with your allocated NUFER MEDICAL sales partner.</p>

4. General Description

The built-in ceramic heater has very good radiation properties and generates invisible infrared radiation of around 3 μm . This radiation spectrum is absorbed very effectively by the skin and causes no harm to the patient's eyes.

5. Assembly

5.1 Minimum Clearance

After you have removed the packaging, compare the unit data on the specification plate with the electrical connection data. Electricity is supplied via a 220–240 V AC 50/60 Hz mains socket with a connection value of 6 A.

Ensure that the wall- and ceiling mount (fixed or mobile) is fastened into solid masonry (brickwork, sand-lime brick or concrete) and that suitable wall-plug screws are used.

Mount the heater head:

- with a clearance of at least 80 cm and no more than 100 cm between the reclining surface and the bottom edge of the heater head.
- with a clearance of at least 50 cm between the ceiling/false ceiling and the top edge of the heater head.

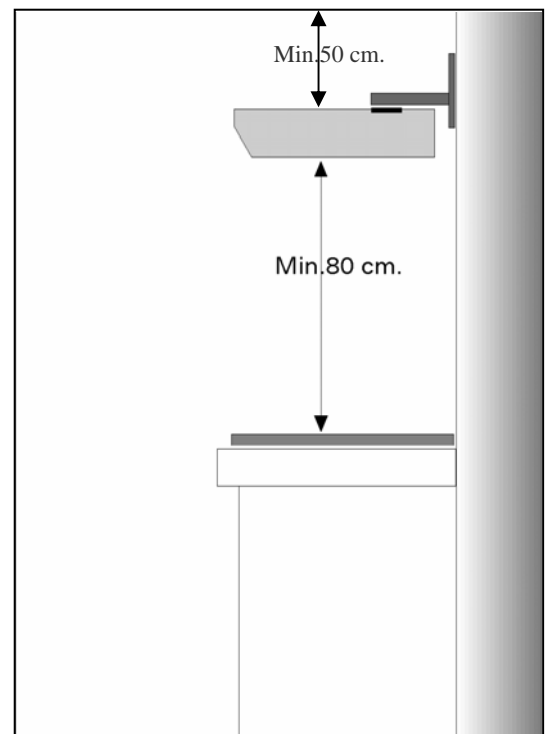

Figure 1



Ensure that there is always a clearance of at least 80 cm between the reclining surface and the bottom edge of the heater head.

Ensure that there is always a clearance of at least 50 cm between the ceiling/false ceiling and the top edge of the heater head.

The thickness of the underlay must also be taken into account.

Neglecting to do so may result in burns or fire.

6. Product description

The CERATHERM 600-3 radiant heater has four programmable heat output levels, which can be selected directly by pressing the buttons [heat level 1-4].

The default settings for the heat levels are 20, 50, 75 and 98%. All levels can be adjusted by a specialist upon request (within certain limits, e.g. safety level no larger than 20%).

All heat outputs above the safety level are monitored with a 15-minute reminder alarm. This alarm is intended as an aid for the user only; it does not relieve the user of a duty to supervise the patient.

An indicator lamp is built in to monitor actual heat output.

The patient is lit by a modern high-power LED lamp, which has the following advantages over a halogen lamp:

- More natural colour temperature (4000°K)
- No UV- or IR-radiation component
- Longer service life
- Lower energy consumption

→ Observe the relevant information in chapter 15 (Lighting)!

The light can be set to one of two brightness levels (default setting: 20% and 100%). These values can be set by a specialist in 10% increments.

The lighting switches on and off gradually, i.e. with a smooth transition, so it has a less disruptive impact on the patient.

In standby mode, the lighting has an automatic shut-off function. If the lighting is switched on and no lighting button has been pressed for 20 minutes, the lighting switches off automatically. This function can be disabled as required.

The installed software version can be displayed as necessary.

The setting of the relevant parameters is described in chapters 18 and 19 of the CERATHERM 600-3 service manual.

6.1 Description of Parts

Underside:



Figure 2

No.	Designation	Function
12	Reflector	Radiates heat
13	Hand grip	Adjusts the radiant heater
14	LED light	Lights the patient -> Observe the relevant information in chapter 15!
15	Ceramic heating element	Generates heat

Table 1

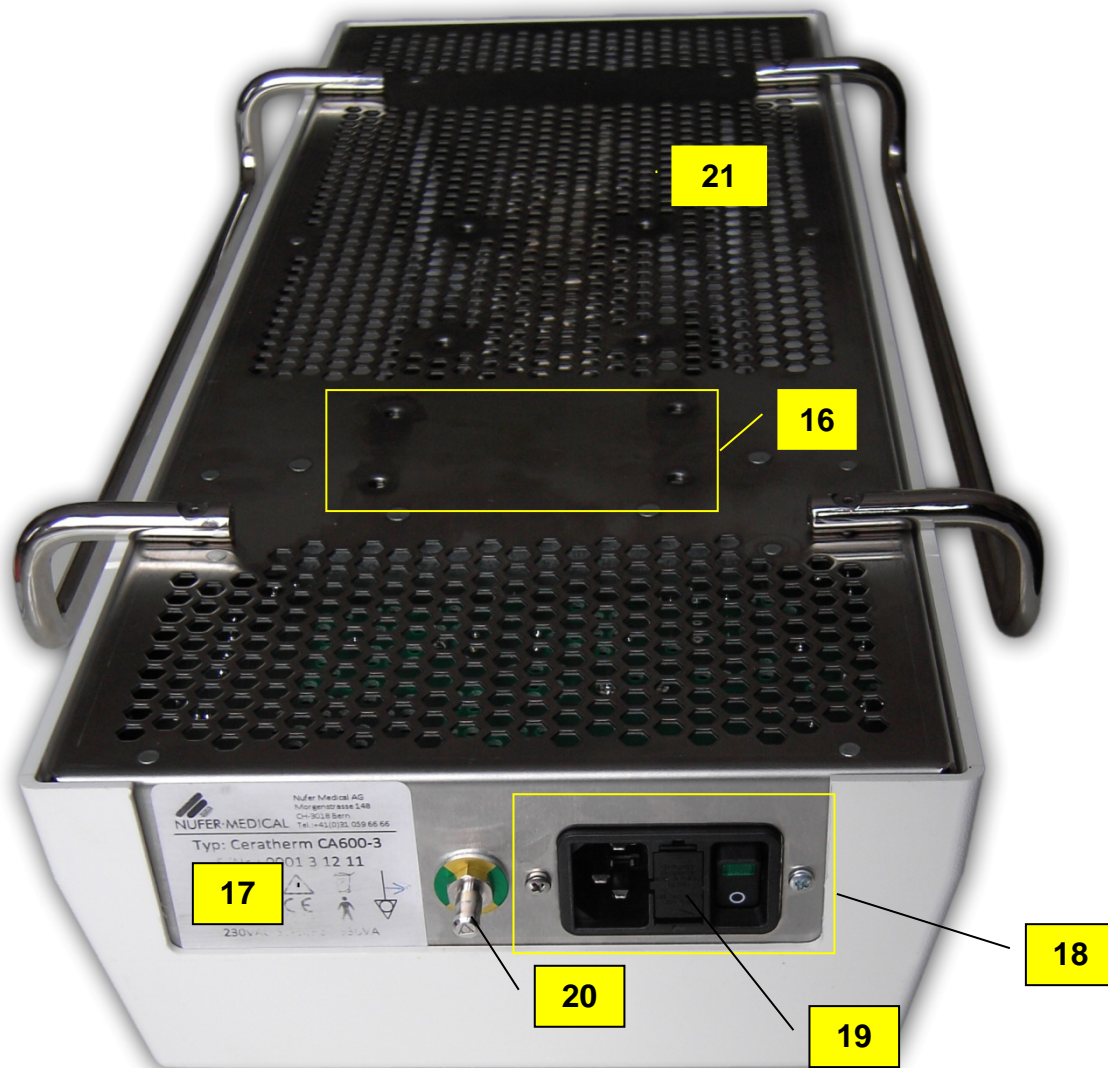
Topside:

Figure 3

No.	Designation	Function
16	Heater head mount	Fastens the heater head to the ceiling/wall and trolley
17	Specification plate	Displays serial number, mains connection, fuse data and various symbols
18	Unit socket	Connects to 220–240 V / 50 Hz power supply
19	Fuses	Main fuses 2 × 3.15 AT
20	Potential equalisation connection	Connects to room's potential connection (room categories 3 and 4)
21	Protective grille	Functions as heat guard and provides ventilation

Table 2

7. Operation

Operation of the CERATHERM 600-3 radiant heater has been kept deliberately straightforward. Use of the unit is largely self-explanatory.

7.1 Master switch

The unit's ON/OFF switch is located on the rear side. This is normally switched on at all times. The heater head itself is switched on/off with ON/OFF button [7] on the front side. If this button is used to switch off the unit, it switches to energy-saving standby mode.

Note	<p>If the unit is switched off at the mains switch while it is not in standby mode (i.e. while heat level 1–4 is active), the mains failure alarm sounds. The unit cannot differentiate between mains failure and being switched off in such a case. Pressing alarm confirmation button [6] during a mains failure alarm silences the buzzer. The alarm LED will continue to flash until the supply voltage returns or the energy storage unit is empty (min. 15 min).</p>
-------------	--

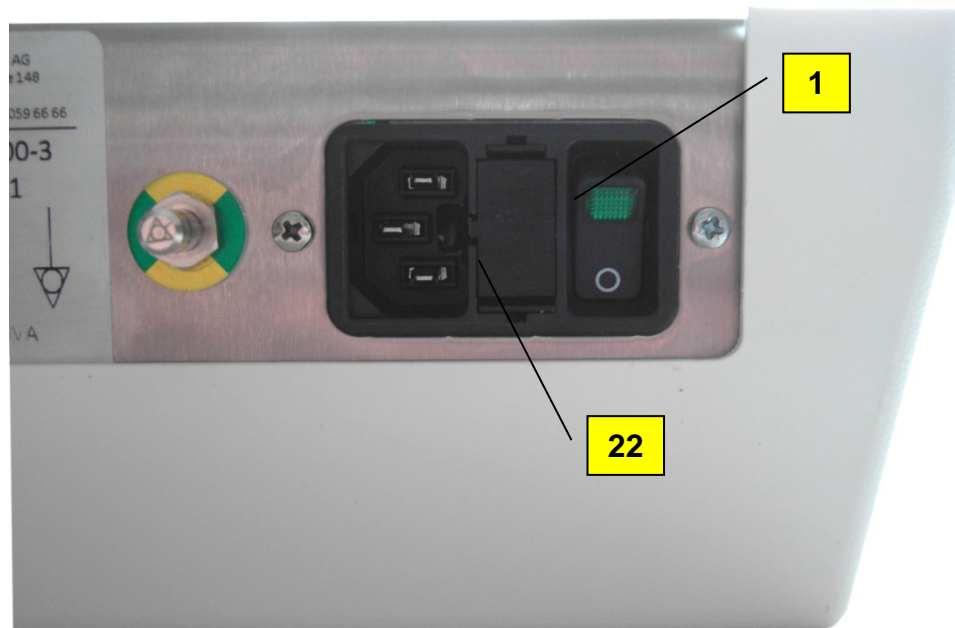
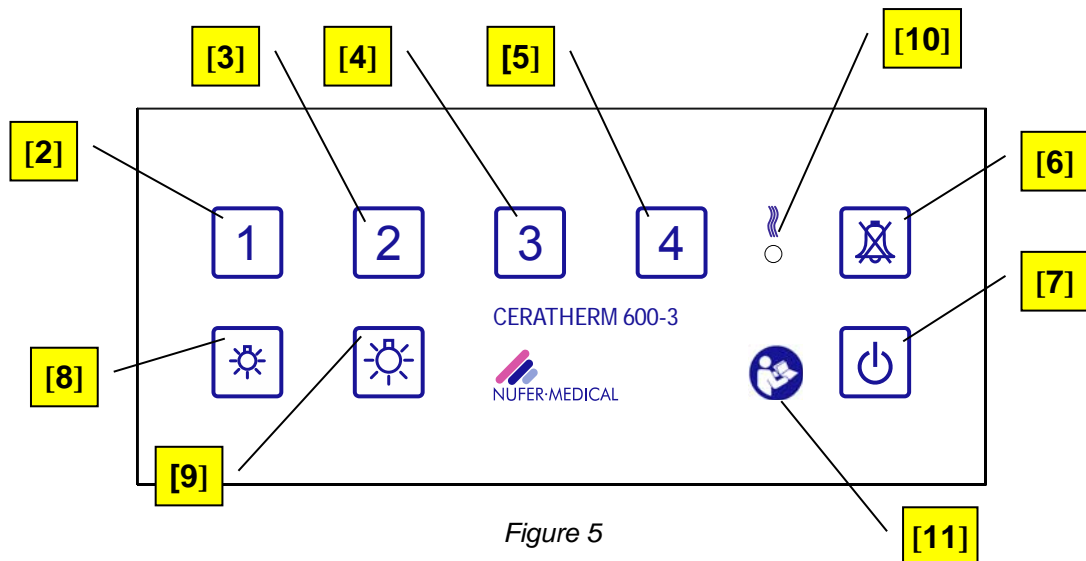

Figure 4

No.	Designation	Function
1	Master switch	Disconnects the radiant heater from the mains supply
22	Fuse holder	Contains two 3.15 AT microfuses (20 × 5 mm)

Table 3

7.2 Control Elements on the Front



No.	Designation	Function
2	Illuminated button: Heat level 1	Sets heat level 1 with 20% ¹
3	Illuminated button: Heat level 2	Sets heat level 2 with 50%
4	Illuminated button: Heat level 3	Sets heat level 3 with 75%
5	Illuminated button: Heat level 4	Sets heat level 4 with 98% ²
6	Illuminated button: Alarm confirmation	Resets an alarm
7	Illuminated button: ON/OFF	On: Level 1 is activated / Off: Heater head on standby
8	Button: LED 20%	Switches LED lighting on and off, at 20%
9	Button: LED 100%	Switches LED lighting on and off, at 100%
10	LED: Heat output indicator	Displays the heat output via differing blink rates
11	Warning: Read manual.	Read through the manual before commissioning.

Table 4

Button illumination:

- Buttons 2–7 are illuminated.
- Buttons 8 and 9 are not illuminated.

Note	When the buttons are referred to in the text below, the number will be given in square brackets [].
-------------	---

¹ Given output corresponds to default settings.

² Cannot be any higher than 98% because of the internal hardware monitoring circuit.

8. Commissioning

When the radiant heater is switched on via the mains switch on the rear side, the unit is initially in standby mode.

1. If you require additional light, switch on the LED lamp with a low [8] or high [9] brightness level.
2. Switch on the heater head by pressing on/off button [7]. The heat output is automatically set to heat level 1 (20%) to keep the reclining surface warm. (The reclining surface is pre-warmed after roughly 5–10 minutes.)
3. If greater output is desired as per table 4, select one of the heat levels 2–4 directly [3,4,5]. The yellow heat output indicator LED [10] displays whether the radiant heater is providing the desired output.
4. If heat level 2, 3 or 4 is selected, a reminder alarm will sound after 15 minutes. If this alarm is not confirmed with alarm button [6] within 8 seconds, output is reduced to the safety level (20%) for safety reasons. If the alarm is confirmed within 8 seconds, the heater will operate for a further 15 minutes, at the previous heat output.
5. The heater head can be switched to standby mode by pressing the green on/off button [7].
6. Once the controls have been set to standby mode via on/off button [7] on the front, the unit can be fully shut down by pressing mains switch [1] on the rear side.

8.1 Adjusting the Heat Output

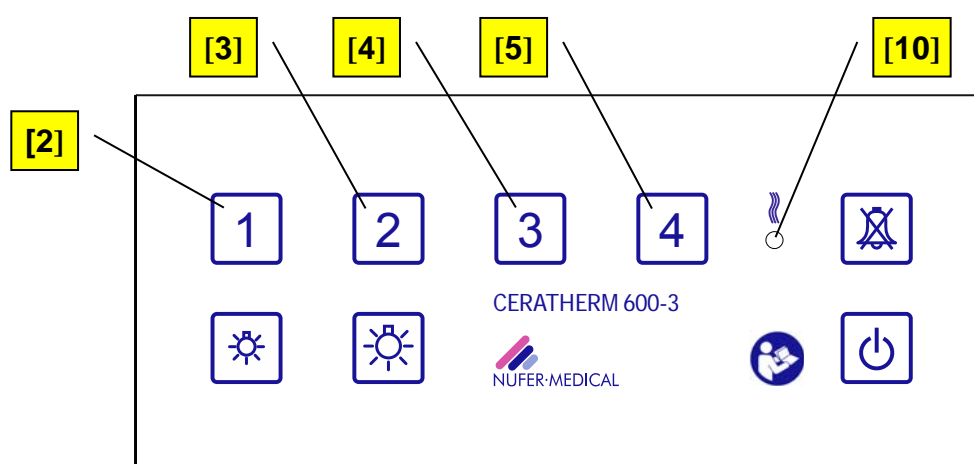

Figure 6

The four-level controls allow heat output to be perfectly adjusted to suit particular requirements. The following standard values are set by default:

Level 1 = 20% Level 2 = 50 % Level 3 = 75 % Level 4 = 98 %

Note	<p>The safety level (level 1) can be set no higher than 20%.</p> <p>For technical reasons, level 4 cannot be set above 98%.</p>
-------------	---

The heat output of the individual levels 1–4 can be customised for particular applications by **authorised maintenance staff**, for example:

Level 1 = max. 20% Level 2 = 40% Level 3 = 60% Level 4 = 80%

8.2 Practical Examples of Output Level Settings

- 1** Level 1: e.g. for pre-heating the reclining surface or keeping it warm, and for continuous operation
- 2** Phase 2: e.g. for normal operation for a baby changing or examination table
- 3** Phase 3: e.g. for additional heat during resuscitation, in the delivery room or operating theatre
- 4** Phase 4: e.g. for increased heating requirements in the operating theatre, for anaesthesia or in the recovery room

8.3 Checking the Set Output

The set output is displayed via heat output indicator LED [10]. The LED signals the activation of the heating element. If the LED is flashing, the heater is active. If the LED is dark, the heat element is switched off. One heat period corresponds to roughly 2 seconds. If a 50% output has been selected, for example, the LED lights up for roughly 1 second and is out for roughly 1 second. The LED lights up longer as output increases.

8.4 Alarm Monitoring

If the unit has been set to a heat output above level 1 for 15 minutes, a reminder alarm is activated. The alarm signal is both acoustic (buzzer sounds in five short intervals) and visual (alarm LED flashes red).

If alarm confirmation button [6] is pressed within 8 seconds of the alarm beginning, the alarm is deactivated for the next 15 minutes and the heater head continues operation at the previous heat output. If no alarm confirmation is given within this 8-second period, heat output is reduced to 20% for safety reasons. The red alarm LED displays this status visually until the heater head is either switched off with on/off button [7] or the alarm is confirmed with

alarm confirmation button [6]. The alarm is deactivated for the next 15 minutes and the heater head continues operation at the previous heat output.

	<p>The patient must never be left unattended on the reclining surface.</p> <p>The supportive alarm monitoring function is not activated at safety level.</p>
---	--

9. LED Lighting

The CERATHERM 600-3 is fitted with a modern LED lamp. This cutting-edge light source has a lower energy consumption and higher service life than other lights. -> Observe the relevant information in chapter 15!

9.1 Operation

The CERATHERM 600-3's LED lighting has two brightness levels, which can be switched on and off as follows:

If the LED lighting is switched off:

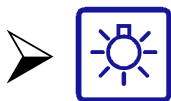

- Press once: LED switches to bright level (default: 100%).
- Press once: LED switches off again.



- Press once: LED switches to low-light level (default: 20%).
- Press once: LED switches off again.

When the lighting is switched on, the brightness can be switched from 20% to 100% or vice versa by pressing the relevant lamp button. The light can be switched off by pressing the previously selected button again.

9.2 Changing the Brightness Values

The brightness values can be set by a specialist in 10% increments from 10–100%.

10. Troubleshooting

The CERATHERM 600-3 controls are able to detect and report the following malfunctions:

1. Supply voltage interruption (mains failure)
2. Circuit breaker interruption (triac)
3. Circuit breaker short-circuit (triac)
4. Safety switch interruption (relay)
5. Safety switch short-circuit (relay)
6. Reduced voltage from 12 V supply voltage
7. Overtemperature in unit

If a mains failure occurs during operation (i.e. at heat level 1–4), an acoustic alarm is given. The alarm LED also flashes at brief intervals. The alarm continues for roughly 15 minutes. The buzzer can be silenced during the alarm by pressing alarm confirmation button [6]. The alarm LED will continue to flash until the supply voltage returns or the energy storage unit is empty (min. 15 min).

If power supply returns, the heater head restarts as follows:

Duration of mains failure less than 15 minutes:

Heater head is activated automatically and continues heating at the previous heat level.

Duration of mains failure longer than 15–20 min.:

The heater head is in standby mode. The unit must be switched on again and the desired heat level must be selected!



The alarm signal can only be given for the full 15 minutes if the heater head was switched on roughly 3–5 minutes before the mains failure, to allow the energy storage unit the charge fully.

In event of errors 2–7, the illuminated heat-level buttons 1–4 [2,3,4,5] are used to display the error code:

Error code	1	2	3	4
Error	Triac error. Short-circuit or safety relay not closed.	Triac error. Interruption.	Overtemperature. Temperature inside heater heat above 50 °C.	Reduced voltage from 12 V supply.
Solution	Switch off radiant heater. Contact customer service (see chapter 1.6).	Switch off radiant heater. Contact customer service (see chapter 1.6).	Switch off heater. Check whether any ventilation openings are blocked. Allow heater head to cool down. Switch heater back on. If the error occurs again, contact customer service (see chapter 1.6).	Switch off radiant heater. Contact customer service (see chapter 1.6).







Table 5

11. Testing the Control Elements

When the controls are switched on, all relevant components (illuminated buttons, buzzer) are briefly switched on to check whether they are functioning correctly.

12. Cleaning/Disinfection

12.1 General information

	<p>The radiant heater must be kept clean and dry. We recommend regular cleaning to preserve the unit's full functionality. Use a cloth that has been moistened with lukewarm water. Alcoholic cleaning agents must be diluted. Do not use any abrasive cleaning agents.</p>
	<p>Before cleaning, ensure that the radiant heater has cooled down and disconnect it from the mains power supply (by disconnecting the mains cable).</p>
	<p>Ensure that no liquid enters the unit or the unit socket.</p>
	<p>If any liquid or powder is spilled, disconnect the radiant heater from the power supply immediately by disconnecting the mains cable. Clean and dry the unit carefully.</p>
	<p>If liquid has entered the unit, discontinue operation of the unit. Contact customer service (see chapter 1.6).</p>
	<p>The radiant heater must not be autoclaved or immersed in liquid. The radiant heater must only be disinfected by wiping over surfaces. Only alcoholic disinfectants may be used.</p>

13. Warranty

13.1 Warranty Period

The warranty period for CERATHERM 600-3 is given in the documents enclosed with the unit. Different warranty periods may apply for different countries. The warranty covers the repair of the unit and the replacement of defective parts in the event of manufacturing or material faults.

13.2 Warranty Restrictions

The warranty **becomes void** in the event of modifications or repairs being performed by unauthorised persons and/or non-observance of the inspection/maintenance intervals. The warranty does **not** include the rectification of malfunctions that have been caused by unintended use, inappropriate handling, penetration of liquids, dirt or normal wear and tear.

NUFER MEDICAL only considers itself responsible for the factors affecting the unit's safety, reliability and performance if the following conditions are met simultaneously:

- a) Assembly, enhancements, reconfiguration, modifications or repairs have been performed by authorised persons as per chapter 1.6.
- b) The electrical installation of the room in which the unit is operated meets the legal and technical requirements for a hospital or clinic mains power supply.
- c) The unit is used in accordance with this instruction manual.

Caution! The radiant heater must only be used with accessories and replacement parts that have been deemed safe to use in a NUFER MEDICAL check (see chapter 16 and 21 in the service manual).

The information given in this instruction manual corresponds to current conditions. Subject to changes that serve technical progress without notice.

14. Disposing of the Unit

The unit must be disposed of in accordance with EU Directive 2002/96/EC. Get in touch with your allocated NUFER MEDICAL sales partner.



15. Specifications*

Model	CERATHERM
Type	600-3
Article number	521A-60020-3
Conformity	CE mark (Directive 93/42/EEC, Annex II)
Notified Body	TÜV SÜD Product Service GmbH, DE-80339 München (CE 0123)
IP protection class	IP20
Contamination level class	2
Electrical protection rating	I (with protective earth connection)
Medicinal product class	IIb (Directive 93/42/EEC, Annex IX, Rule 9)
Applied industrial standards:	-EN 60601-1:2007 -EN 60601-2-21:2010 -EN 60601-1-2:2015
In accordance with the Directive	2011/65/EU (RoHS II)
Mains connection voltage	230 V +/-10%, 50–60 Hz
Power consumption, standby	0.03 VA
Power consumption, max.	630 VA
Fuses	2 x 3.15 AT microfuses, 5 x 20mm (in the unit socket) 1 x 800mAT microfuse, 5 x 20mm (internal on the powerboard)
External conditions during <i>transport</i>	-Temperature: -10 to +50 °C -Relative air humidity: 20 to 90% (no condensation)
External conditions during <i>storage</i>	-Temperature: -10 to +50 °C -Relative air humidity: 20 to 90% (no condensation)
External conditions during <i>operation</i>	-Temperature: +5 to +30 °C -Relative air humidity: 20 to 90% (no condensation)
Heating element	Ceramic, 600 W, wavelength 2-10µm (IR-B/C)
Lighting	LED, 1 x 3W / 700mA / 4.5V, colour temperature 4000°K, without built-in power source
Alarms	-Acoustic and visual after 15 minutes, with automatic heat output reduction to 20% of max. output. -Mains failure -Technical malfunction (with error code)
Operating position	Horizontal, heat radiating vertically downwards
Assembly options	As per with accessories, chapter 16
Transport	In original packaging
Safety checks	Every 12 months as per service manual specifications, chapter 20
Disposal	In accordance with Directive 2002/96/EC. Get in touch with your allocated sales partner.
Dimensions	270 x 105 x 540 mm (W x H x L)

Weight	4.3 kg (without accessories)
Material, housing	ABS (temperature-resistant plastic)
Material, chassis	CNS (stainless steel)
Material, reflector	CNS (stainless steel)

*NUFER MEDICAL reserves the right to make changes to the unit that may affect these specifications, at any time and without notice.

16. Accessories

Regarding the accessories approved for the CERATHERM 600-3 radiant heater:

	<p>With regard to assembly and use, observe the assembly and operating instructions supplied with the accessories. NUFER MEDICAL is in no way responsible for errors or accidents that are the result of non-compliance with the instructions on assembly, operation, care, maintenance and any other content given in the instruction manual supplied with the accessories. The same applies for repair work performed on the accessories if such work is performed by unauthorised persons or if unapproved original components are used.</p>
--	---

16.1 Wall mount, fixed, non-pivoting (optional)

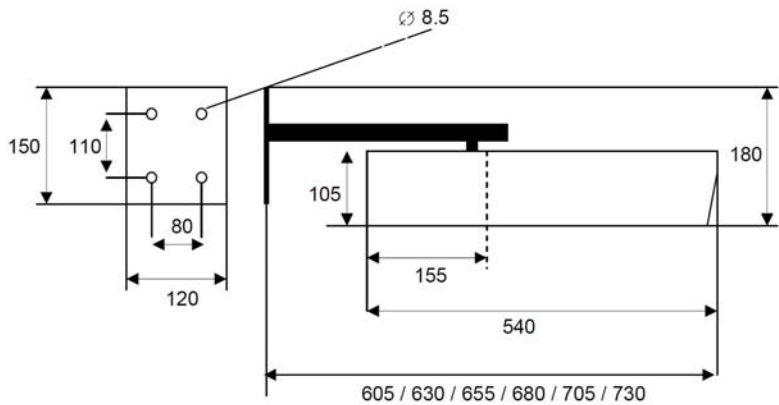
	
Article number: 521A-60023-3	Non-pivotable. Distance from wall adjustable as per drawing.

16.2 Wall mount with double-joint arm (optional)

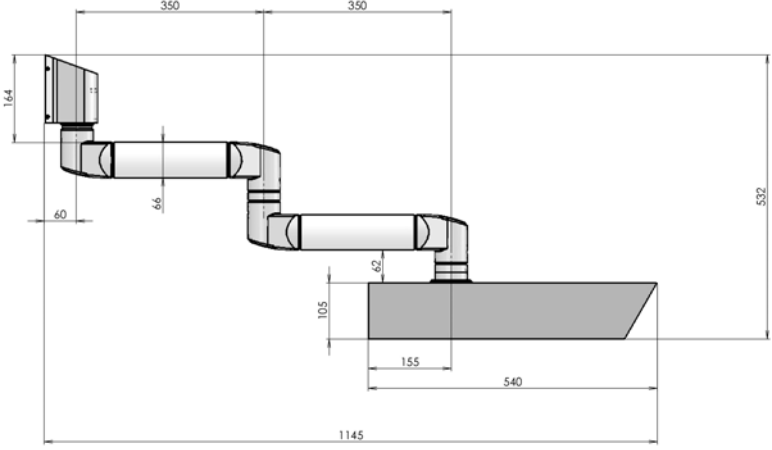
	
Article number: 521A-60022-3	Pivotal, 360°. No height adjustment. Arm length as per drawing.

16.3 Wall mount with double-joint arm, long, with height adjustment (optional)

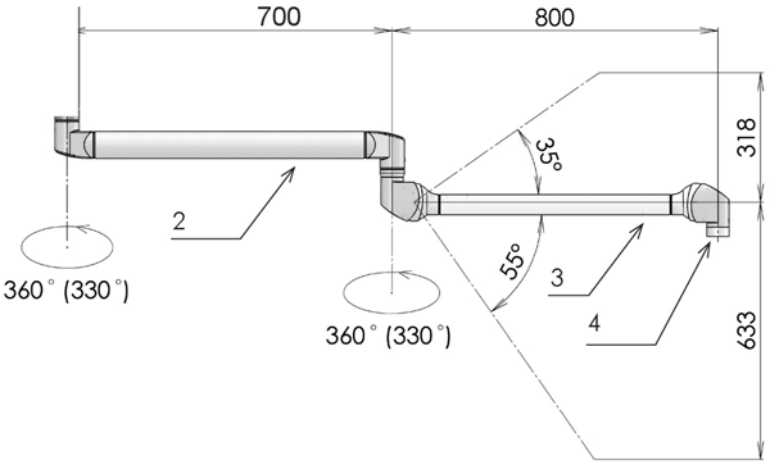
	
Article number: 521A-60025-3	Pivotal, 360°. With height adjustment. Arm length as per drawing.

16.4 Ceiling mount with double-joint arm, long, with height adjustment (optional)

<p>Article number: 521A-60024-3</p>	<p>Pivotable, 360°. With height adjustment. Arm length as per drawing. Ceiling tube length customer-specific.</p>

16.5 Mobile stand, with height adjustment (optional)

<p>Article number: 521A-60035-3</p>	<p>With height adjustment. Triple-bar trolley base with two brakes. Dimensions as per drawing.</p>

Notes:

17. Repair Request Form

REPAIR REQUEST FORM			
Address of national representative:			
Customer name and address:			
Name of contact:		Tel. :	
Invoice number:			
Model: CERATHERM 600-3		Accessories:	
Serial number:			
Detailed description of failure or problem:			
Anticipated work/repair:			
Repair	<input type="checkbox"/>	Description:	
Warranty repair	<input type="checkbox"/>		
Delivery of replacement unit	<input type="checkbox"/>		
Other	<input type="checkbox"/>		
Date:		Signature:	

Intended recipients	Users
Status	Valid
Date	01/30/2019
Doc. version	5
Software version	Version from CA6 V1.30
Authors	Nufer Medical AG / DU
File name	14.171.D_GA_Ceratherm_600_3_EN



NUFER MEDICAL AG

Morgenstrasse 148
CH-3018 Bern / Switzerland

Tel. +41 (0)31 958 66 66

info@nufer-medical.ch
www.nufer-medical.ch

